



ADVANTAGE
LITES & LOUVERS

(Formerly Leslie Locke & LLBP)

415 Concord Avenue, Bronx, NY 10455 - 1004
Tel: 718-585-3230 • Fax: 718-292-2243
www.a-ll.com

INSTALLATION INSTRUCTIONS

VISION-LITE GLASS FRAMES MODEL# T4G, 784G*, 88G



WOOD DOORS :

Model #	T4G	784G*	88G
Rough Cut-Out	1 7/8"	1 5/8"	1 1/4"
Glass Size	1"	1"	3/4"

* Formerly **84G**

1. Add dimensions shown in chart (right) to exposed glass size for determining rough opening and cut glass size.
2. On Model T4G, install clips (optional) into putty stop slots, see drawing for correct orientation.
3. Insert front frame half into rough cut out. On 784G and 88G, drill proper size holes at locations. On T4G, hook edge of clips (optional) over door skin.
4. Install glass using putty or glazing tape.
5. Secure back frame to door, use fasteners as furnished. **DO NOT SUBSTITUTE.** Kit No. 115127 must be used for 784G and 88G in wood door installation in classified fire doors. Kit contains 24 each bolts and rivets.

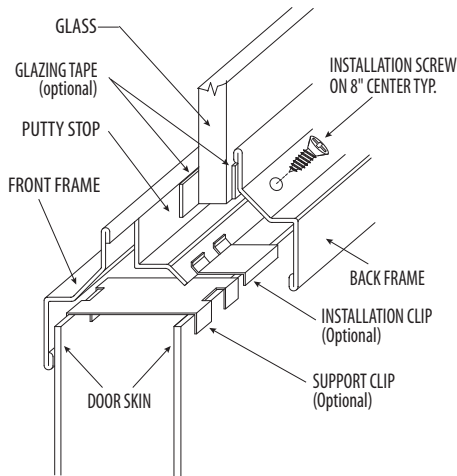

T4G Typical Construction

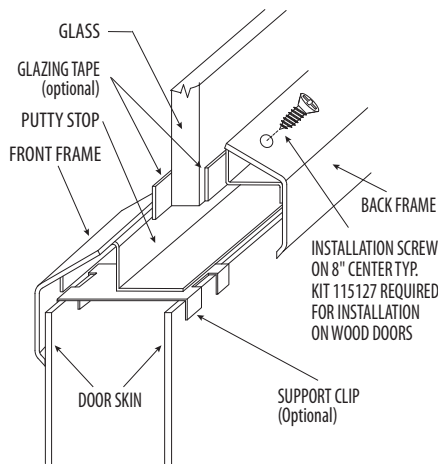

784G Typical Construction

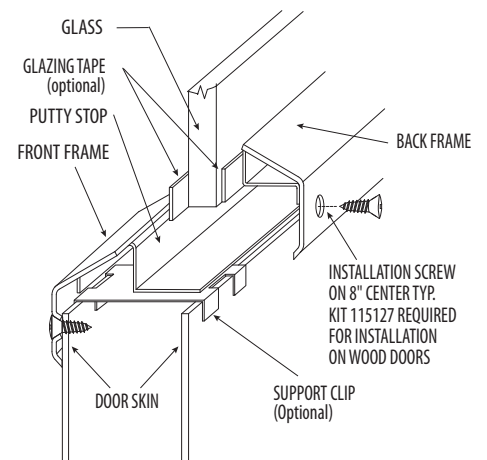

88G Typical Construction

HOLLOW METAL DOORS :

1. Add dimensions shown in chart above to exposed glass size for determining rough opening and cut glass size.
2. On Model T4G, install clips into putty stop slots (optional). See drawing for correct orientation.
3. Insert front frame into rough cut out. On 784G and 88G, use #8 countersunk sheet metal screws to secure door. On T4G, hook edge of clips over door skin.
4. Install glass using putty or glazing tape.
5. Secure back frame to door. Use screws as furnished. **DO NOT SUBSTITUTE.**
NOTE : Optional Kit 115127 can be ordered if desired for 784G and 88G.

ADVANTAGE LITES & LOUVERS Vision-Lite Kits are U.L. Listed when installed in classified Fire Doors, using approved installation methods. Consult factory for specific requirements.

VISION LITE



This product is Listed by
UNDERWRITERS LABORATORIES, INC 
 and Bears the Mark:

- **Frame structures are UL 10-B listed when installed in classified fire doors, using approved installation methods.**
- Uses 1/4" through 1/2" glass depending on model.
 NOTE: Use labeled glass only in UL listed installation (glass not included)
- For use with 1 3/8" or 1 3/4" (depending on model) wood or metal doors
- See individual model specifications for specific model information and ordering data
- All fire door glass light frames are pretreated with degreasing and conversion coating systems
- **Finishes are baked-on powder coated paint. Available in Gray, Beige, Bronze, and AMS Beige**
- Vision-Lites can be supplied in any specified size that doesn't exceed the minimum and maximum dimensions. However, best service and price is available on two inch even multiples.
- Maximum sizes approved by UL 10-B for 20 minute and 45 minute doors.
 - T4G - 22 1/2" X 54"
 - 784G* - 24" X 54"
 - 88G - 24" X 54"

The policy of Advantage Lites & Louvers, Inc is one continual improvement in design and manufacturing wherever possible to assure still finer products. Therefore, specifications and product availability are subject to change without notice.

* Formerly **84G**

Table of size Limitations for UL Rated Doors

U.L. LISTING OF VISION LITE PANELS				
Door	Model (Size in Square Inches)			
Type	UL Rating Minutes	784G	88G	T4G
Wood	20	1296 ①	1296 ①	100 ②
Wood	45	1296 ①	1296 ①	100 ①
Wood	90	100 ②	100 ②	100 ②
Steel	45	1296 ①	1296 ①	1200 ①
Honeycomb Core	90	100 ②	100 ②	100 ②
Steel: Stiffened	45	1296 ①	1296 ①	1200 ①
	90	100 ②	100 ②	100 ②
Steel: Composite	45	1296 ①	1296 ①	1200 ①
	90	100 ②	100 ②	100 ②

note: ① Maximum Dimension 54"
 ② Maximum Dimension 33"



(Formerly Leslie Locke & LLBP)

415 Concord Avenue, Bronx, NY 10455 - 1004
 Tel: 718-585-3230 • Fax: 718-292-2243
 www.a-ll.com

a ZERO INTERNATIONAL, INC. company



since 1923

www.zerointernational.com